

**Part Number: PT767-35051**

**Kit Contents**

Item #	Quantity Req.	Description
1	1	Divider Screen
2	1	LH Bracket with Warning Label
3	1	RH Bracket without Warning Label

**Hardware Bag Contents**

Item #	Quantity Req.	Description
1	4	Knob
2	2	Clamp Plate
3	2	M8 Sq Head Bolt

**Additional Items Required For Installation**

Item #	Quantity Req.	Description
1		
2		
3		

**Conflicts**

Camper Shell
--------------

**Recommended Tools**

<b>Personal &amp; Vehicle Protection</b>	<b>Notes</b>
None	
<b>Special Tools</b>	<b>Notes</b>
None	
<b>Installation Tools</b>	<b>Notes</b>
None	
<b>Special Chemicals</b>	<b>Notes</b>
None	

**General Applicability**

All Models
------------

**Recommended Sequence of Application**

Item #	Accessory
1	
2	
3	





\*Mandatory

**NOTE:** Part number of this accessory may not be the same as the part number shown.

**Vehicle Service Parts** (may be required for reassembly)

Item #	Quantity Req.	Description
1		
2		
3		

**Legend**

	<b>STOP:</b> Damage to the vehicle may occur. Do not proceed until process has been complied with.
	<b>OPERATOR SAFETY:</b> Use caution to avoid risk of injury.
	<b>CAUTION:</b> A process that must be carefully observed in order to reduce the risk of damage to the accessory/vehicle and to ensure a quality installation.
	<b>TOOLS &amp; EQUIPMENT:</b> Used in Figures calls out the specific tools and equipment recommended for this process.
	<b>REVISION MARK:</b> This mark highlights a change in installation with respect to previous issue.

## Procedure

Care must be taken when installing this accessory to ensure damage does not occur to the vehicle. The installation of this accessory should follow approved guidelines to ensure a quality installation.

These guidelines can be found in the "Accessory Installation Practices" document.

This document covers such items as:-

- Vehicle Protection (use of covers and blankets, cleaning chemicals, etc.).
- Safety (eye protection, rechecking torque procedure, etc.).
- Vehicle Disassembly/Reassembly (panel removal, part storage, etc.).
- Electrical Component Disassembly/Reassembly (battery disconnection, connector removal, etc.).

Please see your Toyota dealer for a copy of this document.

## 1. Bracket Installation

- (a) Remove end caps from the back of each vehicle bed side rail. (Fig. 1-1)

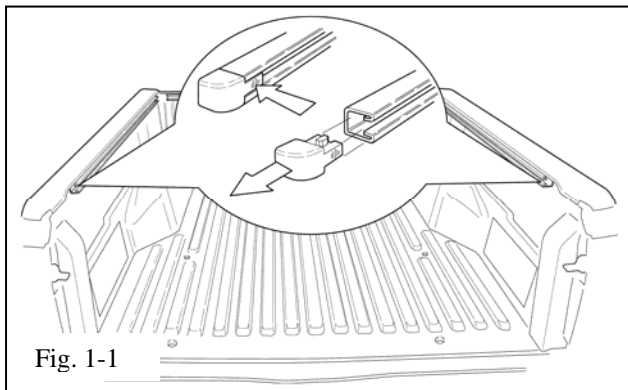

Fig. 1-1

- (b) Slide one clamp plate into each side rail. (Fig. 1-2)

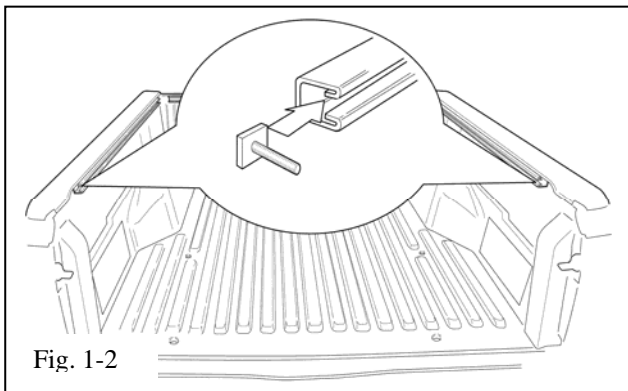

Fig. 1-2

- (c) Install the LH Bracket (with the WARNING label) onto the LH clamp plate threaded stud. (Fig. 1-3)

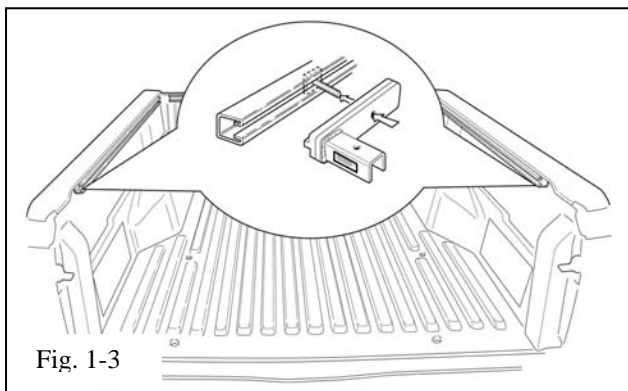
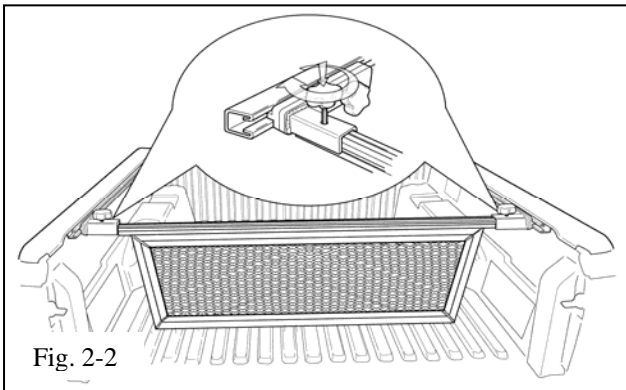
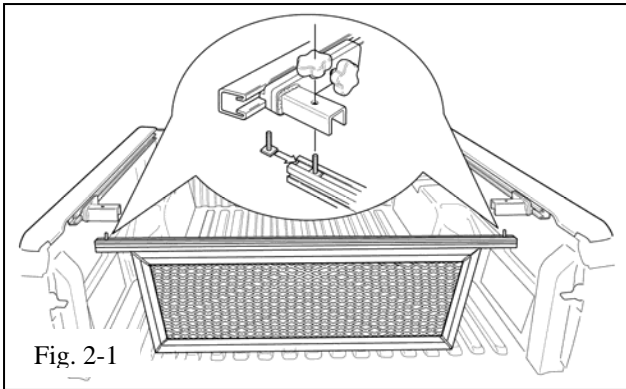
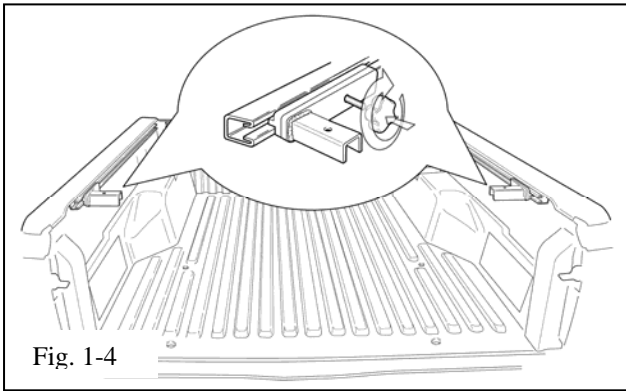

Fig. 1-3



- (d) Screw a knob onto the clamp plate threaded stud. Do not completely tighten the knob. Leave it loose enough so that the bracket can still be moved fore and aft on the side rail. (Fig. 1-4)
- (e) Repeat steps (1c) & (1d) for the RH bracket.

## 2. Divider Screen Installation

- (a) With the divider screen standing vertical in the rear of the bed behind the brackets, insert an M8 square head bolt into each end of the slot on the cross screen extrusion. Slide each bolt in approximately 6" from the extrusion end (Fig. 2-1).
- (b) By tilting the top of the divider screen slightly forward, locate screen up into the brackets. As you lift each end of the screen up into position, slide the M8 bolts over until they align with the hole in the bracket. Screw a knob onto each M8 bolt. Do not completely tighten the knobs. (Fig. 2-2)
- (c) Reinstall the two end caps removed in step (1a).
- (d) The vehicle bed side rails have internal stop detents every four inches. With all knobs loose, slide the screen/bracket assembly fore or aft to the desired location. As you tighten one of the side knobs, continue to slide the bracket fore and aft until you feel the clamp plate lock into one of the rail stop detents. Tighten the knob and repeat on the other side. Finally, tighten the two top knobs.

**TOYOTA TACOMA 2005 - CARGO DIVIDER**

Checklist - these points **MUST** be checked to ensure a quality installation.

Check:

Accessory Function Checks

Securely Installed

Look For:

Check to see that all four knobs are hand tight and the screen/bracket assembly will not slide in the vehicle bed rails.